

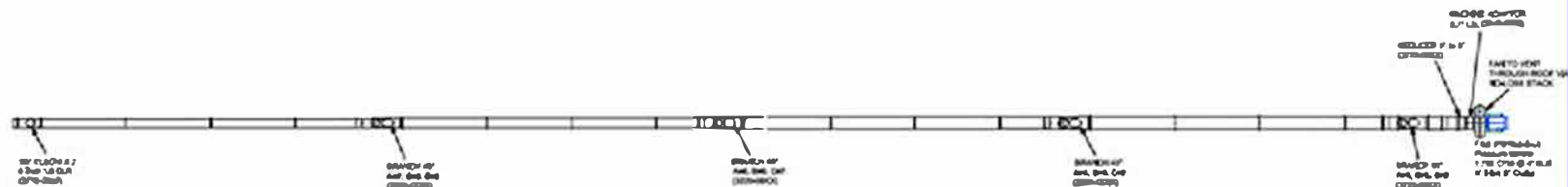

Air Cleaning Specialists Inc.
 11088 Gravois Ind. Ct.
 St. Louis MO 63128
 636-349-4400
 636-349-0556 Fax

PLAN/TOP VIEW



NOTE: -FANS ARE NOT INCLUDED IN DUCTING QUOTE
 -FANS CAN BE CHANGED PER APPLICATION
 -ALL TO BE MOUNTED BY CUSTOMER FROM BRIDGE
 -CONCEPT DRAWING ONLY. LOCATIONS APPROXIMATE
 -DUCT SIZING BASED ON TYPICAL USE OF SYSTEM

THIS PRINT IS THE PROPERTY OF
 AIR CLEANING SPECIALISTS, INC.
 11088 GRAVOIS INDUSTRIAL CT
 ST. LOUIS, MO 63128
 636 349-4400
 AND IS ON LOAN TO THE RECIPIENT
 SUBJECT TO RETURN UPON DEMAND.
 IT'S CONTENTS ARE CONFIDENTIAL
 AND MUST NOT BE COPIED OR SUB-
 MITTED TO OUTSIDE PARTIES FOR
 USE OR EXAMINATION.

AIR CLEANING SPECIALISTS, INC.

Fume-A-Vent 5 Drop 6" Hose Reel Duct
 System with SlipFit Ducting

FAV-SF-HR5D6

REF. NUMBER

13-122723D

QUOTE #

00

REVISIONS

SHEET NAME

DETAIL



DRAWING TITLE

HOSE REEL
 DUCTING
 5- DROP

DRAWN: CODY BINGAMAN

CHECKED: JIM GRAYEM

PROJECT NAME
 NORDFAB GALV.

DATE	VIEW
12/23/13	DETAIL

SIZE	DWG NO.	REV.
A	1	0

EDGE
System

The *EDGE*[®]
Self-Sealing Round Duct System



ACS

Air Cleaning Specialists, Inc.

(800) 878-5030

The EDGE® – Features, Benefits & Materials

The EDGE® System will eliminate the sealing of all connections in your spiral pipe system. This system will not only provide a labor savings for the installer, it is a high efficient duct system and also great for exposed systems.

FEATURES

- 1 All fittings will have a factory installed EPDM gasket, which has an operating temperature rating of -20°F to 212°F.
- 1 The smoke and flame spread rating is 0/0.
- 1 The gasket construction is of a black EPDM base with a wiper for machine application and a green EPDM hollow seal that will act as the sealing section.
- 1 The gasket is attached to the fitting with a 180° hemmed edge that will hold the gasket in place, as shown in the diagrams to the right.
- 1 The connections are secured with self-tapping sheet metal screws per SMACNA standards.
- 1 The EDGE® System allows for substantial space for insertion of the screws, because the gasket is located on the leading EDGE of the fitting. (NOTE: The use of sheet metal screws with a rubber gasket would insure that all screw holes are sealed as well.
- 1 The EDGE® System has been tested in accordance to SMACNA's Air Duct Leakage Test Manual and meets SMACNA Class 3 leakage standards.

BENEFITS

- 1 Stronger fitting
- 1 Eliminates sharp edge
- 1 Consistent diameter
- 1 Factory installed resulting in a cost savings
- 1 The EDGE® gasket is treated with anti-friction coating for easy installation.

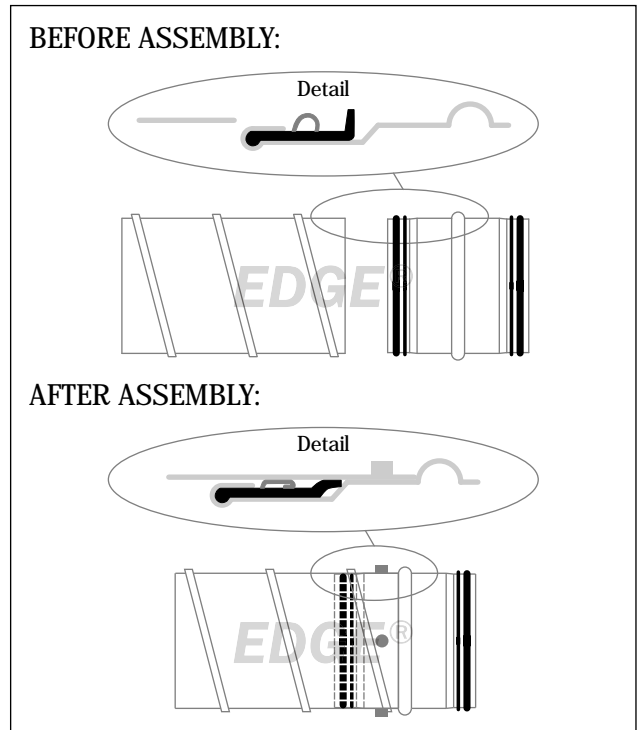

The EDGE® – Fittings & Materials

Fittings: 4" - 10" (all sizes), 12" - 60" (even sizes only)

Materials: Galvanized, Galvaneal, Stainless Steel Type 304 & 316, Aluminum.

All fittings will be fabricated, except for Galvanized Stamped Fittings® listed below:

Elbows	4" - 12" = Stamped/Stitch Welded
Reducers	4" - 18" = Spun
Bellmouths	4" - 12" = Stamped 14" - 36" = Spun
90° Tee	4" - 12" = Fabricated body with Stamped Saddle Tap
90° Tap	4" - 12" = Stamped
All Other Fittings	Any fitting can be fabricated with gasket attached. All products will be fabricated per SMACNA standards and gauges. All fabricated fittings conform to SPIDA dimensional data.

The EDGE® – Construction

CONSTRUCTION (GAUGE):

- 1 All duct and fittings are made per SMACNA's Duct Construction Standards (+10" W.G.).
- 1 Stamped Fittings are all 22 or 24 gauge. Spun Fittings are all 20 gauge.
- 1 The following table shows diameter and gauges:

Diameter	Spiral Duct	Fabricated Fittings
4" - 24"	26 ga.	24 ga.
26" - 36"	24 ga.	22 ga.
38" - 60"	22 ga.	Please Specify

Stamped Fittings®	4"	5"	6"	7"	8"	9"	10"	12"	14" - 36"
GDSE	24 ga.	22 ga.	22 ga.	22 ga.	22 ga.	22 ga.	22 ga.	22 ga.	N/A
GDSE1	24 ga.	24 ga.	24 ga.	24 ga.	24 ga.	24 ga.	24 ga.	22 ga.	N/A
GDST	24 ga.	24 ga.	24 ga.	24 ga.	24 ga.	24 ga.	24 ga.	24 ga.	N/A
GBT0 - stamped	24 ga.	24 ga.	24 ga.	24 ga.	24 ga.	24 ga.	24 ga.	24 ga.	N/A
GBT0 - spun	N/A	N/A	N/A	N/A	N/A	N/A	N/A	N/A	20 ga.
GSPR - spun	20 ga.	20 ga.	20 ga.	20 ga.	20 ga.	20 ga.	20 ga.	20 ga.	20 ga.

CONSTRUCTION (PIPE):

- 1 Spiral pipe
- 1 Calibration of spiral is required by The EDGE® System manufacturer, Stamped Fittings Inc.

CONSTRUCTION (FITTINGS):

All EDGE® fittings, 4"– 60", will have a factory installed gasket that is attached to the fitting with a 180° hemmed edge for strength, rigidity and maintaining proper tolerances.

CONSTRUCTION (GASKET):

- 1 The EDGE® gasket consists of a two-part EPDM rubber sealing material.
- 1 The base EPDM (black material) is classified according to ASTM D2000-86 M3BA 810 B13 C12 F17.
- 1 The sealing EPDM (green material) is classified according to ASTM D2000-86 M8BA 507 B13 C12.
- 1 The operating temperature is -20°F to 212°F.
- 1 The smoke and flame spread is in accordance to ASTM E-84-91A.

PRESSURE CLASS:

- 1 The EDGE® System has been tested and meets the requirements of SMACNA's Leakage Class 3.

JOINT CONNECTIONS:

- 1 All fittings are manufactured to slip fit into spiral duct. Any fitting to fitting connection can use a fitting coupling.

The EDGE® – Installation Instructions

The EDGE® System fittings are made to fit tight, assuring a proper seal. Care should be taken when handling these fittings as damage could result in an improper fit and a difficult installation process.



WHEN INSTALLING:

1. Place the hemmed EDGE of the fitting in the spiral pipe then apply pressure and the fitting will slip into place, stopping at the bead/pipe stop.
2. Placement of the fastening screws should be opposite from one another, evenly spaced around the circumference (see diagram). Screws should be placed approximately 1/2" from the bead in order to avoid damaging The EDGE® gasket. In the event of incorrect installation, holes caused by the screws must be sealed before reassembly.
3. Quantities and sizes to be used are listed in the table below.

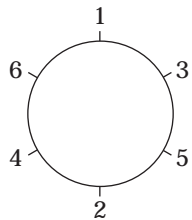

Spiral Duct Diameter	Screw Diameter	Quantity
3" - 5"	1/8"	2
6" - 10"	1/8"	3
12" - 24"	1/8"	4
26" - 36"	1/8"	6





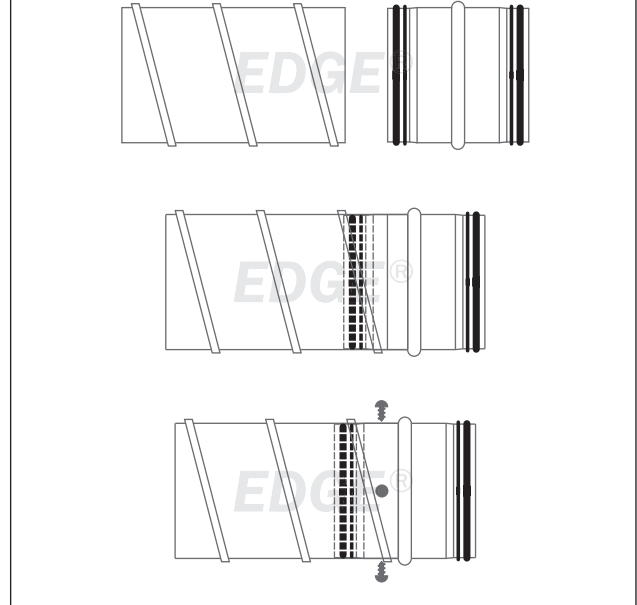

4. Always start the first fastener at the largest radial gap between fitting and duct. Be sure to achieve even distribution around the circumference.

ASSEMBLY:

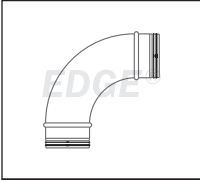
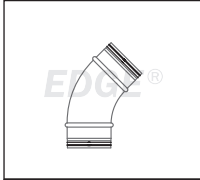
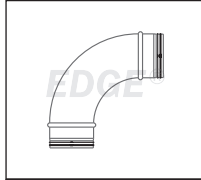
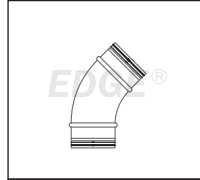
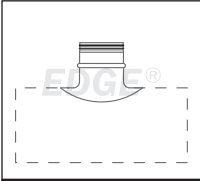
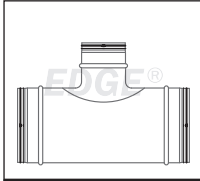
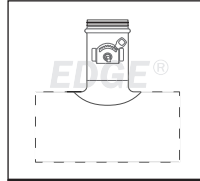
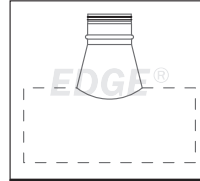
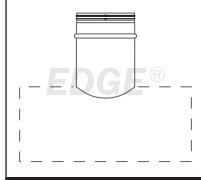

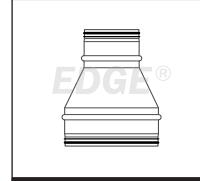
Patent Pending US 2006-0006610A1

The EDGE® – Products

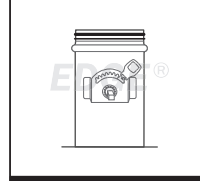
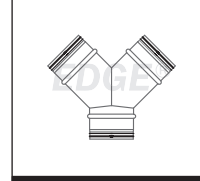
 GDSE90	 GDSE45	 GDSE190	 GDSE145	 GE90/GE190	 GE45/GE145
 GDST	 GTDST	 GDSTRT	 GDSTD	 GC	 GCT
 GCRT	 GCD	 GST	 GT	 GSRT	 GSTD
 GL	 GLT	 GLRT	 GLD	 GSPR	 GR
 GER	 GCTO	 GBTO	 GBTOD	 GPC	 GD
 FC	 GEP	 GBRT	 GSTO	 GSTOD	 GY

The EDGE® – Products



GRY

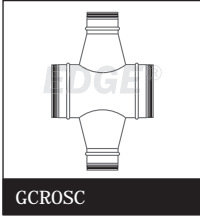

GCROSC

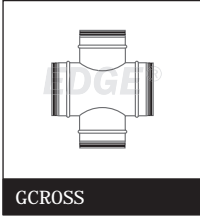

GCROSS

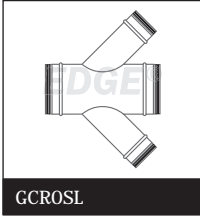

GCROSL

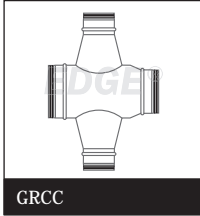

GRCC

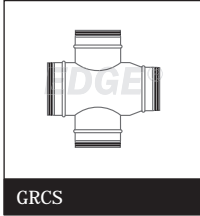

GRCS

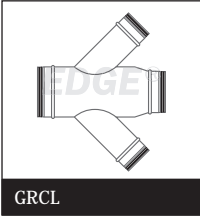

GRCL

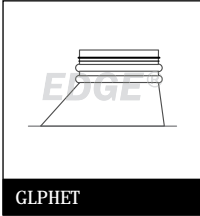

GLPHET

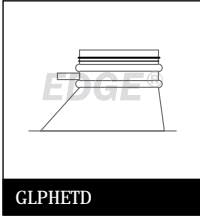

GLPHETD

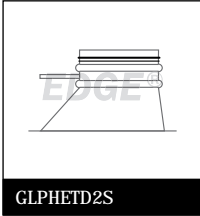

GLPHETD2S



GLPHETDHD

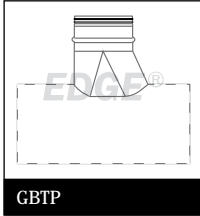

GBTP

The EDGE® – Product Specifications

Gasket 90° Die Stamped 1.5
CLR Elbow (GDSE90)

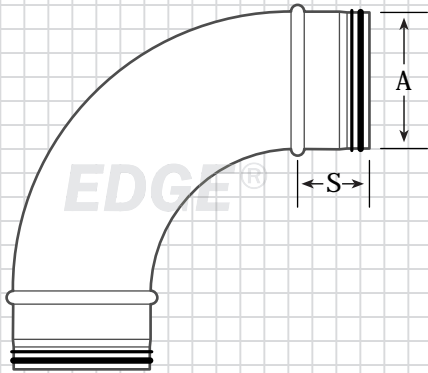

Gasket 45° Die Stamped 1.5
CLR Elbow (GDSE45)

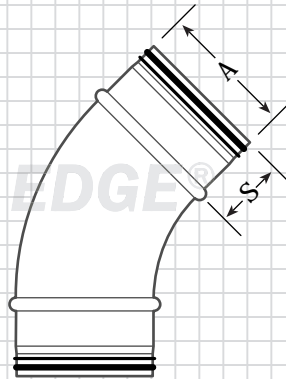

A	S
4"	2"
5"	2"
6"	2"
7"	2"
8"	2"
9"	2"
10"	2"
12"	2"

Gasket 90° Die Stamped 1.0
CLR Elbow (GDSE190)

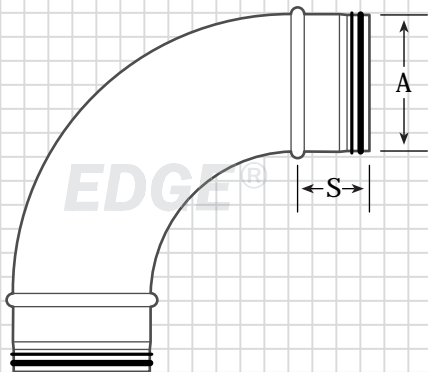

Gasket 45° Die Stamped 1.0
CLR Elbow (GDSE145)

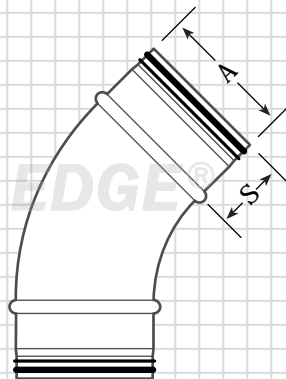

A	S
4"	2"
5"	2"
6"	2"
7"	2"
8"	2"
9"	2"
10"	2"
12"	2"

Gasket Gorelocked Elbows

Gasket 90° 5-Piece 1.5 CLR Elbow (GE90)

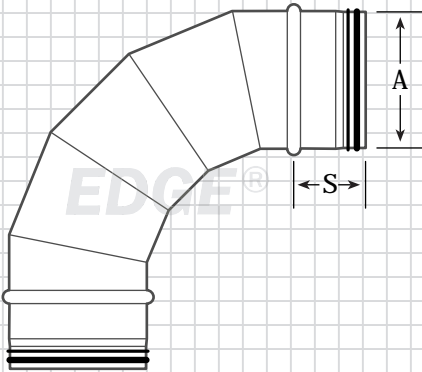

Options Available

- n Specify CLR (1.5, 1.0, etc.)
- n Specify Degree (15°, 22.5°, 30°, 45°, 60°, 90°, etc.)
- n Up to 30° = 2 Piece
- n 30°+ up to 60° = 3 Piece
- n 60°+ up to but not including 90° = 4 Piece
- n 90° = 5 Piece

Key

A = 4" - 10" (all sizes), 12" - 60" (even sizes only)
S = 2"

Gasket 45° 3-Piece 1.5 CLR Elbow (GE45)

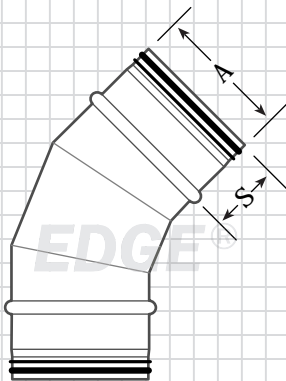

The EDGE® – Product Specifications

Gasket 90° Die Stamped Saddle Tap (GDST)

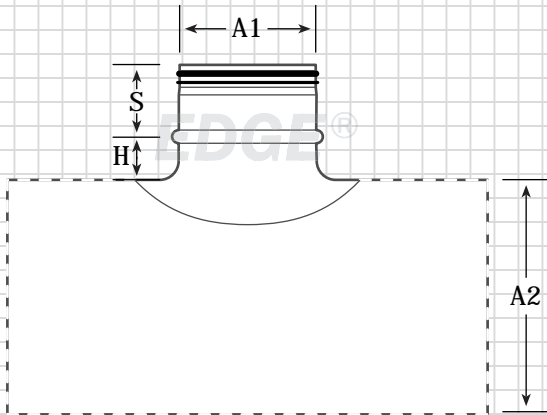

* Field installed fitting

Gasket 90° Tee with Die Stamped Saddle Tap (GTDST)

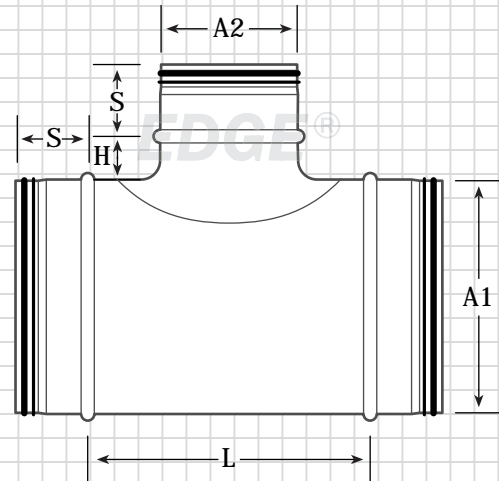

Gasket 90° Reducing Tee with Die Stamped Saddle Tap (GDSTRT)

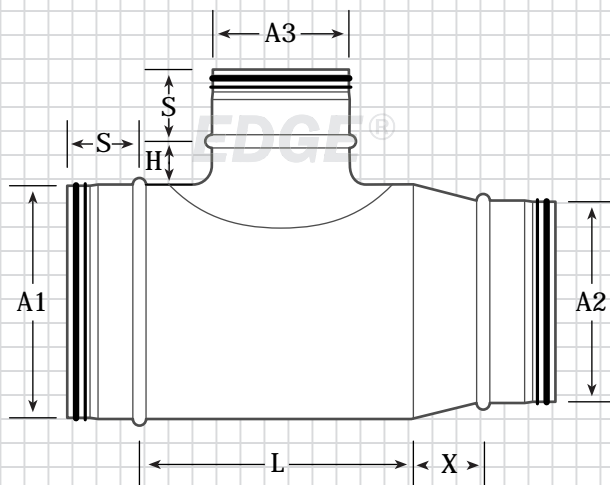

Key (GDST)

A1 = 4", 5", 6", 8", 10", 12"
 A2 = Up to 24" (A2 is greater than or equal to A1)
 S = 2"
 H = 3/4" (where A1 = 6" or less),
 1" (where A1 = 8" or more)

Key (GTDST)

A1 = Up to 24" (A1 is greater than or equal to A2)
 A2 = 4", 5", 6", 8", 10", 12"
 S = 2"
 H = 3/4" (where A1 = 6" or less),
 1" (where A1 = 8" or more)
 L = A2 + 4"

Key (GDSTRT)

A1 = Up to 24" (A1 is greater than or equal to A3)
 A2 = Up to 24" (A2 is less than A1)
 A3 = 4", 5", 6", 8", 10", 12"
 S = 2"
 H = 3/4" (where A3 = 6" or less),
 1" (where A3 = 8" or more)
 L = A3 + 4"
 X = A1 - A2 (4" minimum)

The EDGE[®] – Product Specifications

Gasket 90° Die Stamped Saddle Tap with Damper (GDSTD)

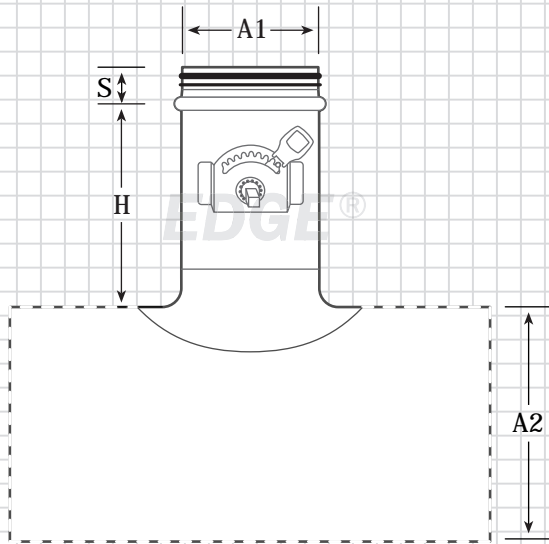

* Field installed fitting

Key (GDSTD)

A1 = 4", 5", 6", 8", 10", 12"

A2 = Up to 24" (A2 is greater than or equal to A1)

S = 2"

H = 7 - 1/2" (for 4")

7 - 3/8" (for 5")

8 - 1/4" (for 6")

8 - 1/2" (for 8", 10" & 12")

Features

- 1 22 Gauge galvanized body

Low-Leakage Dampers

- 1 2" Stand-off
- 1 Nylon bushings
- 1 Locking handle for adjustment of damper - ease of balancing
- 1 3/8" Continuous square rod through damper

The EDGE® – Product Specifications

Gasket 90° Conical (GC)

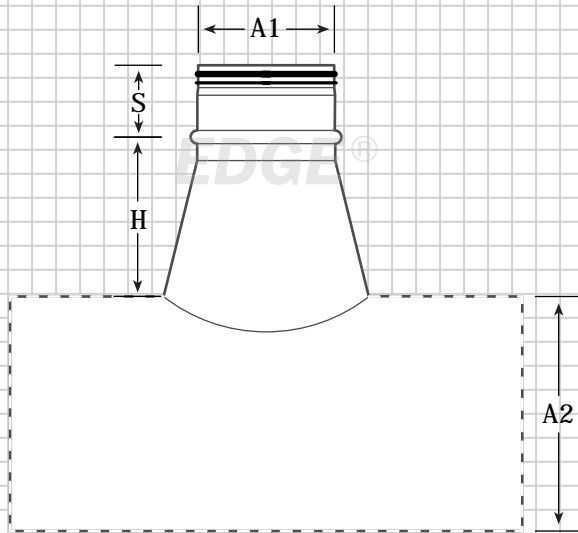

* Field installed fitting

Gasket 90° Conical Tee (GCT)

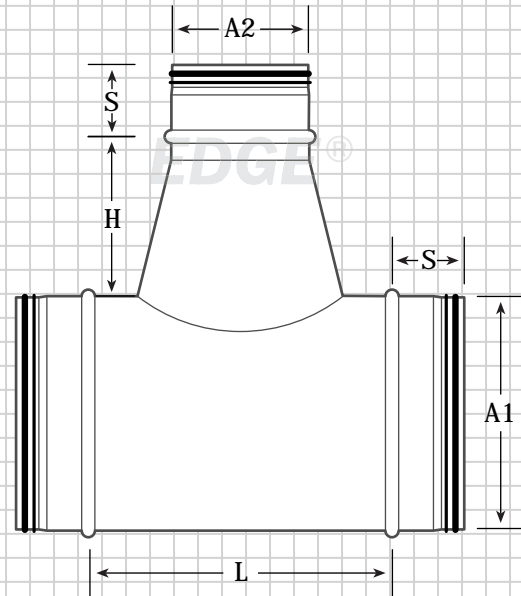

Gasket 90° Conical Reducing Tee (GCRT)

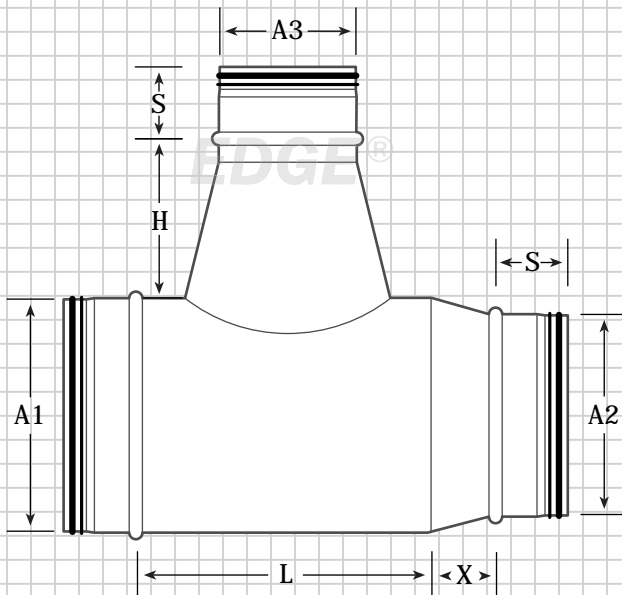

Key (GC)

Sizes Available for A1:
 4" - 10" (all sizes), 12" - 60" (even sizes only)
 A2 is greater than A1
 S = 2"
 H = 6"

Key (GCT)

Sizes Available for A1 & A2:
 4" - 10" (all sizes), 12" - 60" (even sizes only)
 A1 is greater than A2
 S = 2"
 H = 5-1/4"
 L = A2 + 4"

Key (GCRT)

Sizes Available for A1, A2 & A3:
 4" - 10" (all sizes), 12" - 60" (even sizes only)
 A1 is greater than A3
 A2 is less than A1
 S = 2"
 H = 5-1/4"
 L = A3 + 4"
 X = A1 - A2 (4" minimum)

The EDGE® – Product Specifications

Gasket 90° Conical with Damper (GCD)

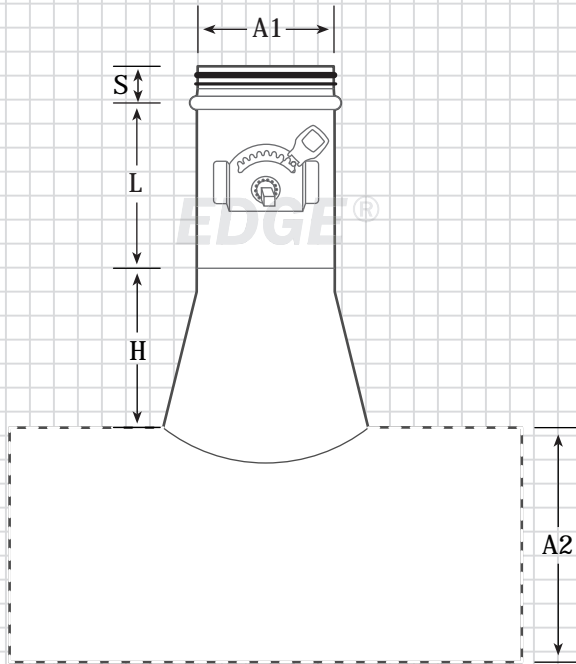

* Field installed fitting

Key (GCD)

Sizes Available for A1:

4" - 10" (all sizes), 12" - 36" (even sizes only)

A2 is greater than A1

S = 2"

H = 6"

L = 4"

Features

1 22 Gauge galvanized body

Low-Leakage Dampers

1 2" Stand-off

1 Nylon bushings

1 Locking handle for adjustment of damper - ease of balancing

1 3/8" Continuous square rod through damper

The **EDGE**® – Product Specifications

Gasket Straight Tap (GST)

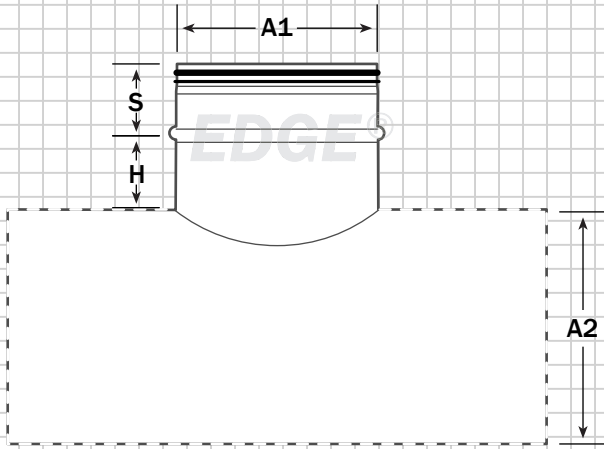

* Field installed fitting

Gasket 90. Tee (GT)

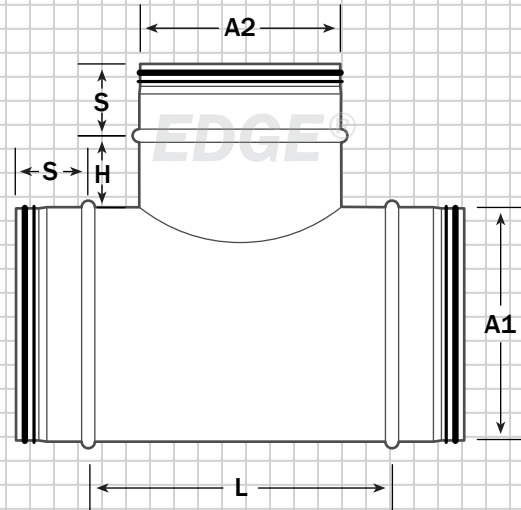

Gasket 90. Straight Reducing Tee (GSRT)

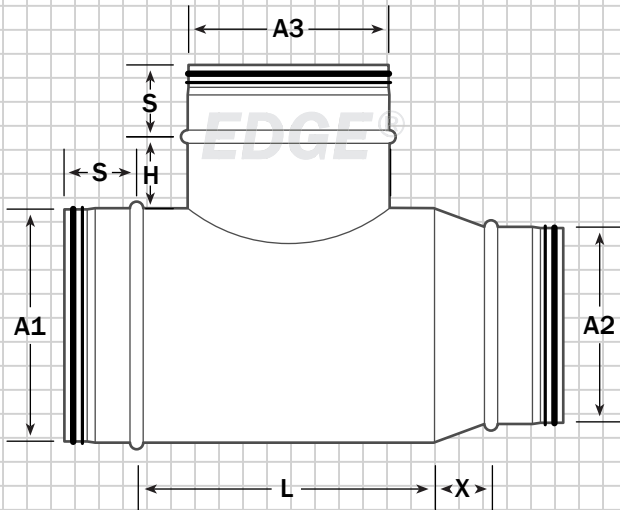

Key (GST)

Sizes Available for A1:
 4"- 10" (all sizes), 12"- 60" (even sizes only)
 A2 is greater than or equal to A1
 S = 2"
 H = 2"

Key (GT)

Sizes Available for A1 & A2:
 4"- 10" (all sizes), 12"- 60" (even sizes only)
 A1 is greater than or equal to A2
 S = 2"
 H = 2"
 L = A2 + 4"

Key (GSRT)

Sizes Available for A1, A2 & A3:
 4"- 10" (all sizes), 12"- 60" (even sizes only)
 A1 is greater than or equal to A3
 A2 is less than A1
 S = 2"
 H = 2"
 L = A3 + 4"
 X = A1 - A2 (4" minimum)

The EDGE® – Product Specifications

Gasket 90 Straight Tap with Damper (GSTD)

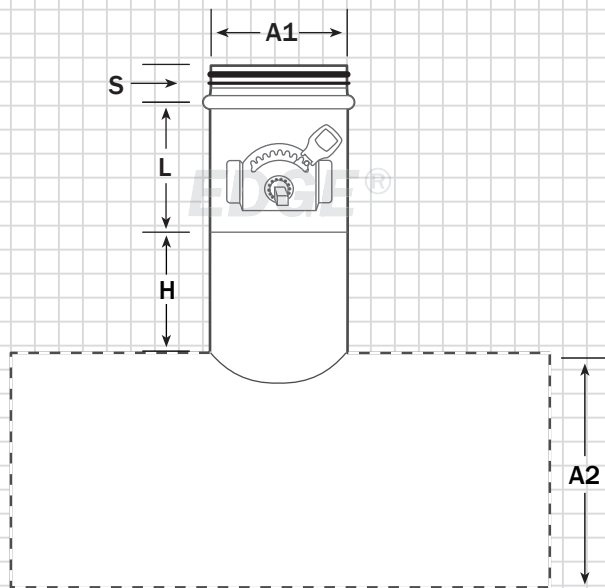

* Fieldinstalled fitting

Key (GSTD)

Sizes Available for A1:
4" - 10" (all sizes), 12" - 36" (even sizes only)
A2 is greater than or equal to A1
S = 2"
H = 4"
L = 4"

Features

- 22Gauge galvanized body

Low-Leakage Dampers

- 2" Stand-off
- Nylon bushings
- Locking handle for adjustment of damper - ease of balancing
- 3/8" Continuous square rod through damper

The EDGE® – Product Specifications

Gasket 45° Lateral (GL)

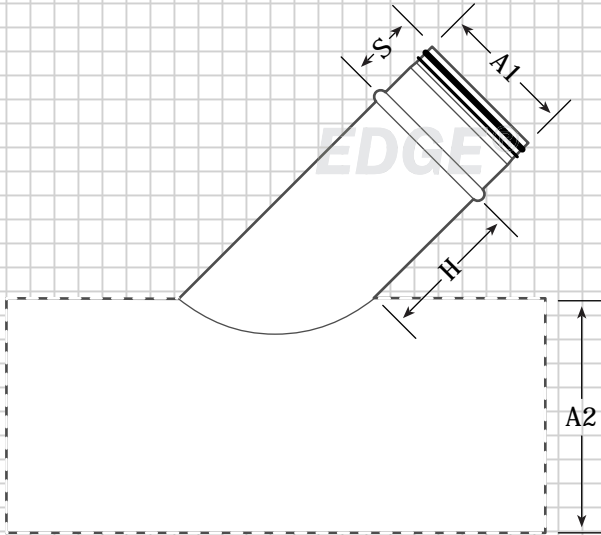

* Field installed fitting

Gasket 45° Lateral Tee (GLT)

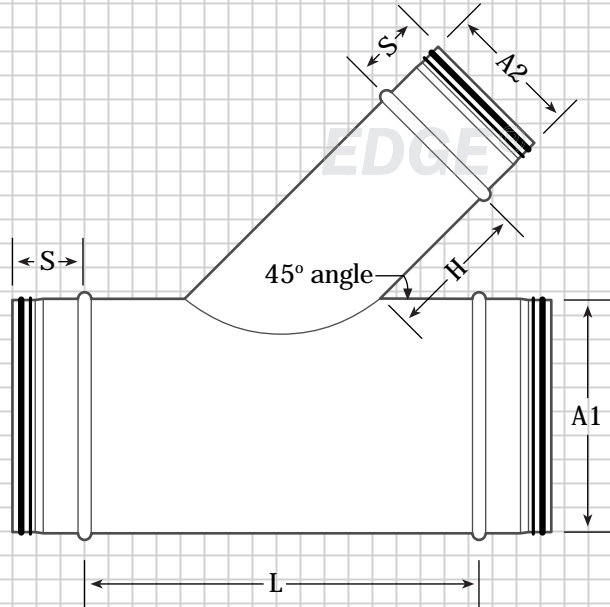

Gasket 45° Lateral Reducing Tee (GLRT)

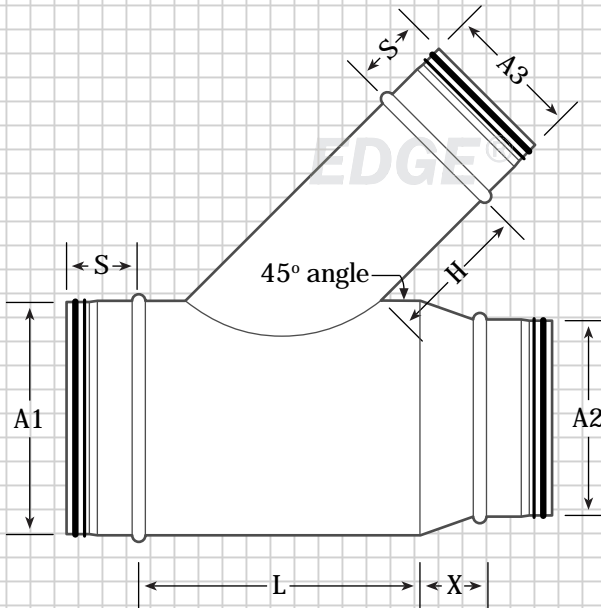

Key (GL)

Sizes Available for A1:
 4" - 10" (all sizes), 12" - 60" (even sizes only)
 A2 is greater than or equal to A1
 S = 2"
 H = 4"

Key (GLT)

Sizes Available for A1 & A2:
 4" - 10" (all sizes), 12" - 60" (even sizes only)
 A1 is greater than or equal to A2
 S = 2"
 H = 4"
 $L = (A2 \times 1.414) + 4"$

Key (GLRT)

Sizes Available for A1, A2 & A3:
 4" - 10" (all sizes), 12" - 60" (even sizes only)
 A1 is greater than or equal to A3
 A2 is less than A1
 S = 2"
 H = 4"
 $L = (A3 \times 1.414) + 4"$
 $X = A1 - A2$ (4" minimum)

The EDGE® – Product Specifications

Gasket 45° Lateral with Damper (GLD)

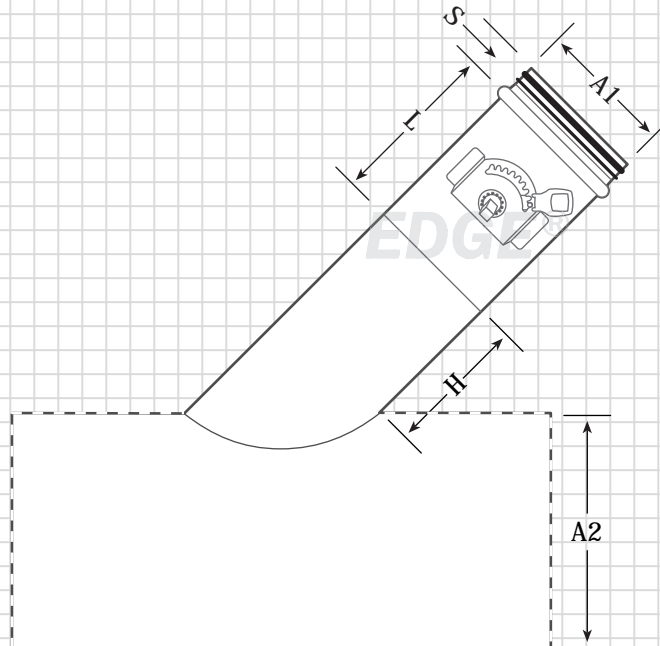

* Field installed fitting

Key (GLD)

Sizes Available for A1:

4" - 10" (all sizes), 12" - 36" (even sizes only)

A2 is greater than or equal to A1

S = 2"

H = 4"

L = 4"

Features

1 22 Gauge galvanized body

Low-Leakage Dampers

1 2" Stand-off

1 Nylon bushings

1 Locking handle for adjustment of damper - ease of balancing

1 3/8" Continuous square rod through damper

The EDGE® – Product Specifications

Gasket Spun Reducer-Concentric (GSPR)

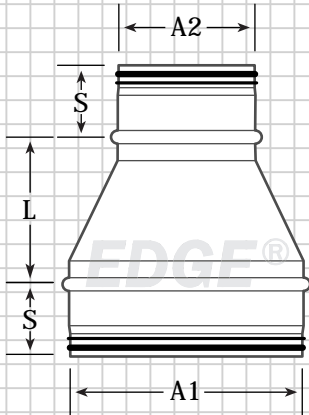

If the difference between A1 and A2 is equal to or greater than 6" and/or A1 is greater than 24", please specify as Gasket Concentric Reducer (GR). This item will be fabricated and not spun.

Key

S = 2"
L = 4" (minimum)

A1	A2	A1	A2
4"	3"	10"	5"
5"	3"	10"	6"
5"	4"	10"	7"
6"	3"	10"	8"
6"	4"	10"	9"
6"	5"	12"	7"
7"	3"	12"	8"
7"	4"	12"	9"
7"	5"	12"	10"
7"	6"	14"	9"
8"	4"	14"	10"
8"	5"	14"	12"
8"	6"	16"	12"
8"	7"	16"	14"
9"	5"	18"	14"
9"	6"	18"	16"
9"	7"		
9"	8"		

4" x 3", 5" x 3", 6" x 3", and 7" x 3" will not have a gasket on the 3" end

The EDGE[®] – Product Specifications

Gasket Concentric Reducer (GR)

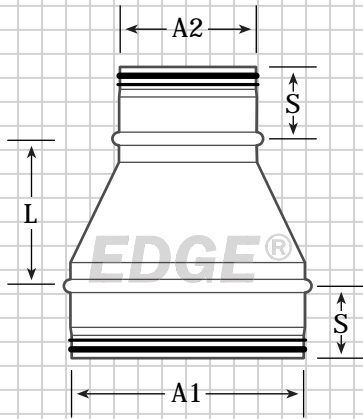

Key (GR)

Sizes Available for A1 & A2:

4" - 10" (all sizes), 12" - 60" (even sizes only)

S = 2"

L = 4" if the change in diameter (A1 - A2) is less than 6"

n If the change in diameter (A1 - A2) is greater than or equal to 6" then L= A1 - A2.

n Please specify any other length, if not the standard.

Key (GER)

Sizes Available for A1 & A2:

4" - 10" (all sizes), 12" - 60" (even sizes only)

S = 2"

L = (A1 - A2) x 2 + 2"

n L minimum = 7- 3/4"

n Please specify any other length, if not the standard.

Gasket Eccentric Reducer (GER)

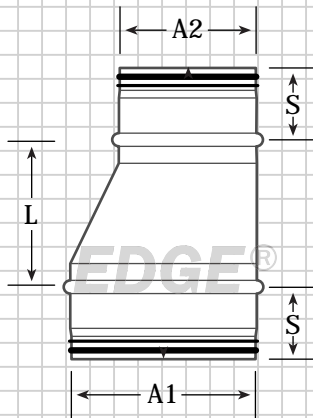

The EDGE® – Product Specifications

Gasket Conical Take-off (GCTO)

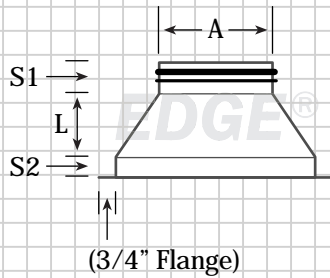

Key

A = 4" - 10" (all sizes), 12" - 22" (even sizes only)
 S1 = 2"
 S2 = 1- 1/4"
 L = 4"

Gasket Bellmouth Take-off (GBTO)

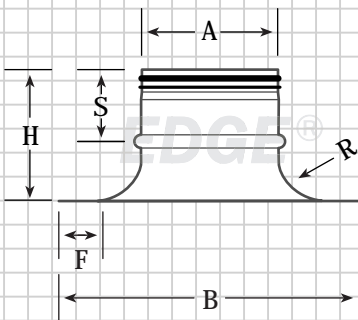

Dimensions

(A)	(S)	(R)	(F)	(H)	(B)
4"	2"	.394"	1"	4.5"	6.5"
5"	2"	.472"	1"	4.875"	8.25"
6"	2"	.787"	1"	4"	8.5"
7"	2"	1.0"	1"	3.25"	10.5"
8"	2"	1.0"	1"	4"	11"
9"	2"	1.0"	1"	3.25"	13"
10"	2"	1.0"	1"	4.5"	13.5"
12"	2"	1.0"	1"	5"	14.5"
14"	2"	2.0"	1"	6"	17"
16"	2"	2.0"	1.5"	8"	20"
18"	2"	2.0"	1.5"	8"	22"
20"	2"	2.0"	1.5"	8"	24"
22"	2"	2.0"	1.5"	8"	26"
24"	2"	2.0"	1.5"	8"	28"
26"	2"	2.0"	1.5"	8"	30"
28"	2"	2.0"	1.5"	8"	32"
30"	2"	2.0"	1.5"	8"	34"
32"	2"	2.0"	1.5"	8"	36"
34"	2"	2.0"	1.5"	8"	38"
36"	2"	2.0"	1.5"	8"	40"

The EDGE® – Product Specifications

Gasket Bellmouth Take-off with Damper (GBTOD)

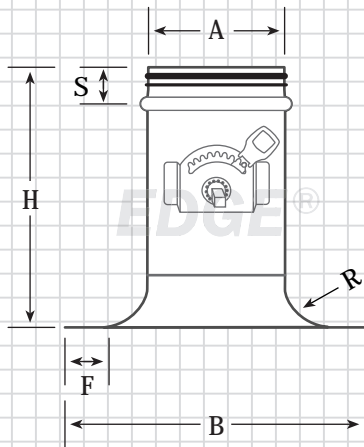

Features

- 1 22 Gauge galvanized body

Low-Leakage Dampers

- 1 2" Stand-off
- 1 Nylon bushings
- 1 Locking handle for adjustment of damper - ease of balancing
- 1 3/8" Continuous square rod through damper

Dimensions

(A)	(S)	(R)	(F)	(H)	(B)
4"	2"	.394"	1"	7.625"	6.5"
5"	2"	.472"	1"	7.75"	8.25"
6"	2"	.787"	1"	9.25"	8.5"
7"	2"	1.0"	1"	8.5"	10.5"
8"	2"	1.0"	1"	9.25"	11"
9"	2"	1.0"	1"	8.5"	13"
10"	2"	1.0"	1"	10"	13.5"
12"	2"	1.0"	1"	10.5"	14.5"
14"	2"	2.0"	1"	11.25"	17"
16"	2"	2.0"	1.5"	13.5"	20"
18"	2"	2.0"	1.5"	13.5"	22"
20"	2"	2.0"	1.5"	13.5"	24"
22"	2"	2.0"	1.5"	13.5"	26"
24"	2"	2.0"	1.5"	13.5"	28"
26"	2"	2.0"	1.5"	13.5"	30"
28"	2"	2.0"	1.5"	13.5"	32"
30"	2"	2.0"	1.5"	13.5"	34"
32"	2"	2.0"	1.5"	13.5"	36"
34"	2"	2.0"	1.5"	13.5"	38"
36"	2"	2.0"	1.5"	13.5"	40"

The EDGE® – Product Specifications

Gasket Pipe Coupling (GPC)

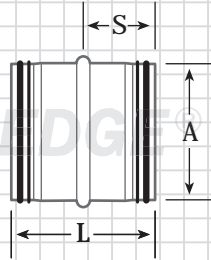

Key (GPC)

A = 4" - 10" (all sizes), 12" - 60" (even sizes only)
 S = 2"
 L = 4"

Gasket Damper (GD)

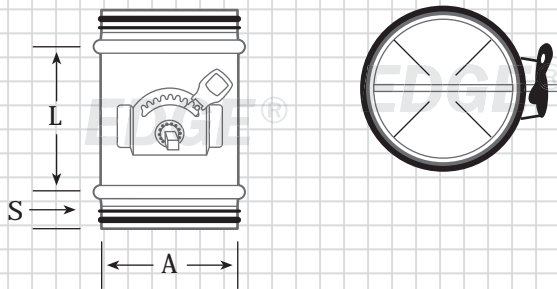

Key (GD)

A = 4" - 10" (all sizes), 12" - 36" (even sizes only)
 S = 2"
 L = 4"

Features

- 1 22 Gauge galvanized body

Low-Leakage Dampers

- 1 2" Stand-off
- 1 Nylon bushings
- 1 Locking handle for adjustment of damper - ease of balancing
- 1 3/8" Continuous square rod through damper

Fitting Coupling (FC)

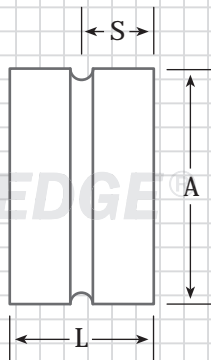

Key (FC)

A = 4" - 10" (all sizes), 12" - 60" (even sizes only)
 S = 2"
 L = 4"

* This product is pipe size for use with fitting to fitting application.

The EDGE® – Product Specifications

Gasket End Plug (GEP)

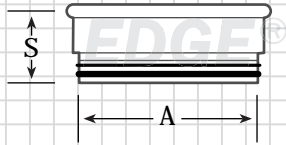

Key (GEP)

A = 4" - 10" (all sizes), 12" - 60" (even sizes only)
S = 2"

Gasket Reducing Bull Head Tee (GBRT)

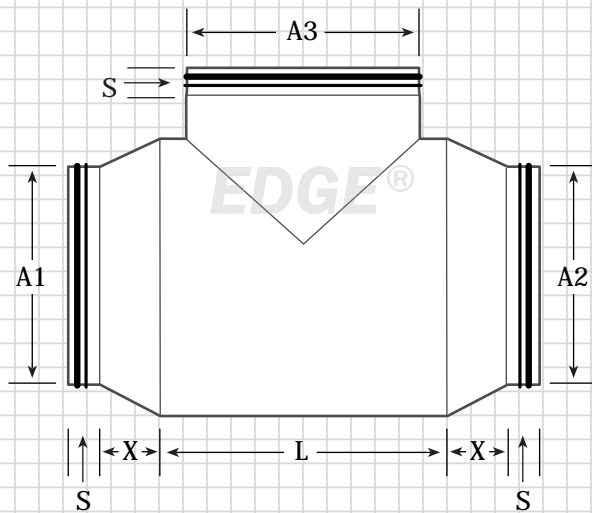

Key (GBRT)

S = 2"
L = A + 4"
X = 4" minimum
A3 > A1 or A2

Order as: in, out, branch (A1, A2, A3)

Gasket Straight Take-off (GSTO)

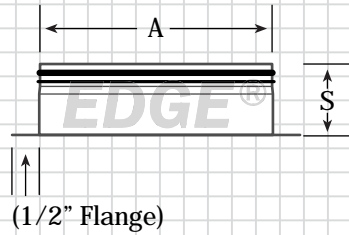

Key (GSTO)

A = 4" - 10" (all sizes), 12" - 60" (even sizes only)
S = 2"

Gasket Straight Take-off with Damper (GSTOD)

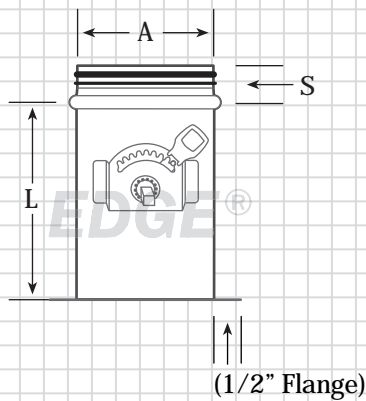

Key (GSTOD)

A = 4" - 10" (all sizes), 12" and 14"
S = 2"
L = 8"

Features

- 1 22 Gauge galvanized body
- 1 Peel & Stick gasket included

Low-Leakage Dampers

- 1 2" Stand-off
- 1 Nylon bushings
- 1 Locking handle for adjustment of damper - ease of balancing
- 1 3/8" Continuous square rod through damper

The EDGE® – Product Specifications

Gasket Y Branch (GY)

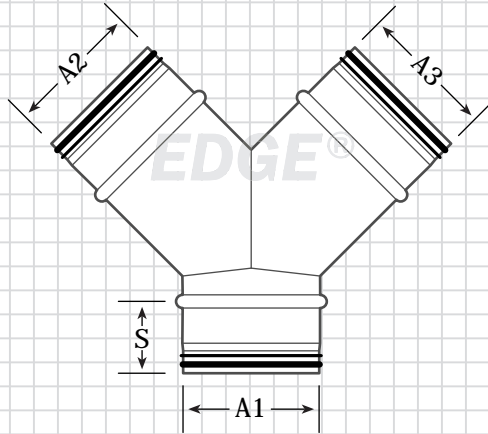

Key

Sizes Available for A1, A2 & A3:

4" - 10" (all sizes), 12" - 60" (even sizes only)

S = 2"

Gasket Reducing Y Branch (GRY)

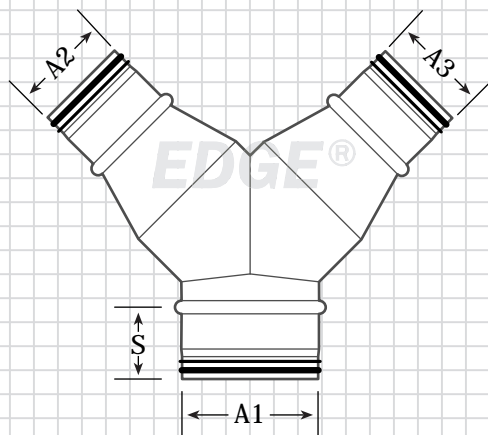

Key

Sizes Available for A1, A2 & A3:

4" - 10" (all sizes), 12" - 60" (even sizes only)

A2 & A3 are less than A1

S = 2"

The EDGE® – Product Specifications

Gasket Conical Cross (GCROSC)

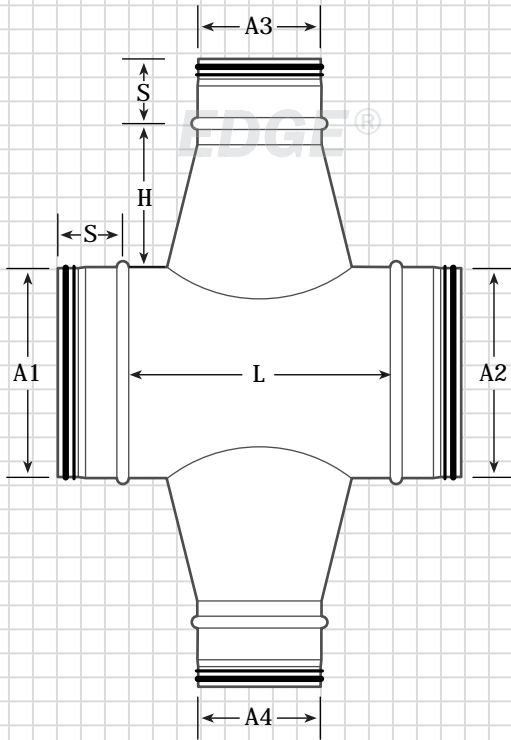

Key (GCROSC)

Sizes Available for A1, A2, A3 & A4:
 4" - 10" (all sizes), 12" - 60" (even sizes only)
 A1 & A2 are greater than A3 & A4 (= 2" min.)
 A3 is greater than or equal to A4
 S = 2"
 H = 4"
 L = A3 + 4"

Key (GCROSS)

Sizes Available for A1, A2, A3 & A4:
 4" - 10" (all sizes), 12" - 60" (even sizes only)
 A1 & A2 are greater than or equal to A3 & A4
 A3 is greater than or equal to A4
 S = 2"
 H = 4"
 L = A3 + 4"

Key (GCROSL)

Sizes Available for A1, A2, A3 & A4:
 4" - 10" (all sizes), 12" - 60" (even sizes only)
 A1 & A2 are greater than or equal to A3 & A4
 A3 is greater than or equal to A4
 S = 2"
 H = 4"
 L = (A3 x 1.414) + 4"

Gasket Straight Cross (GCROSS)

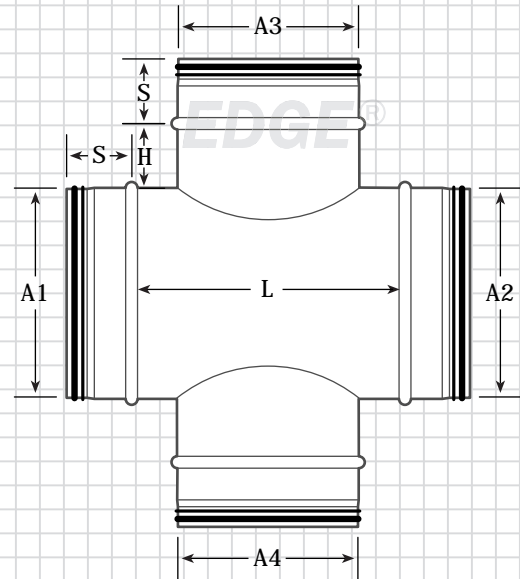

Gasket 45° Lateral Cross (GCROSL)

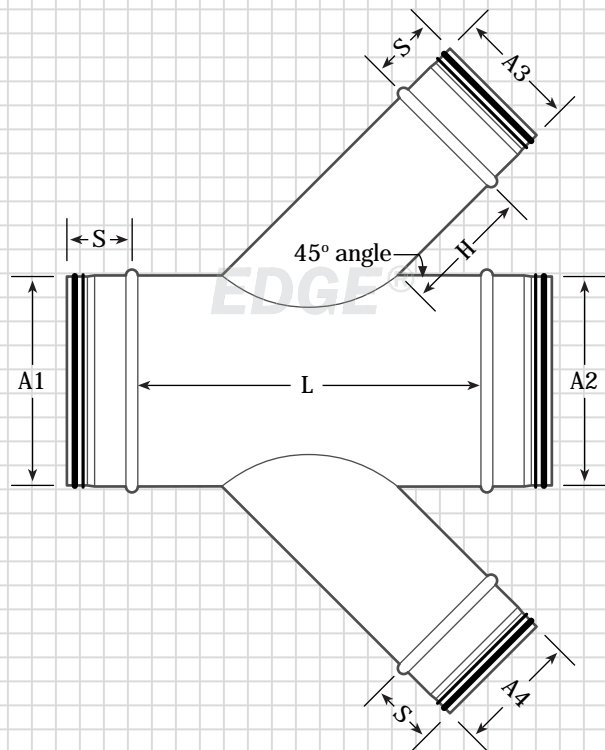

The EDGE® – Product Specifications

Gasket Reducing Conical Cross (GRCC)

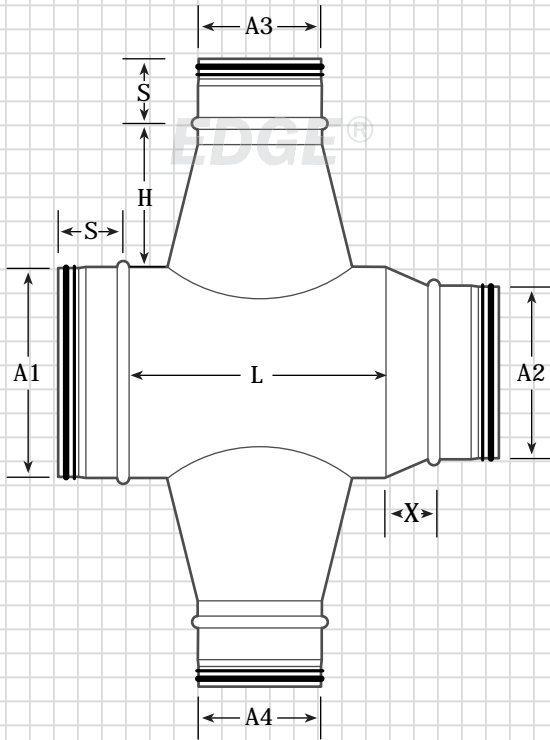

Gasket Reducing Straight Cross (GRCS)

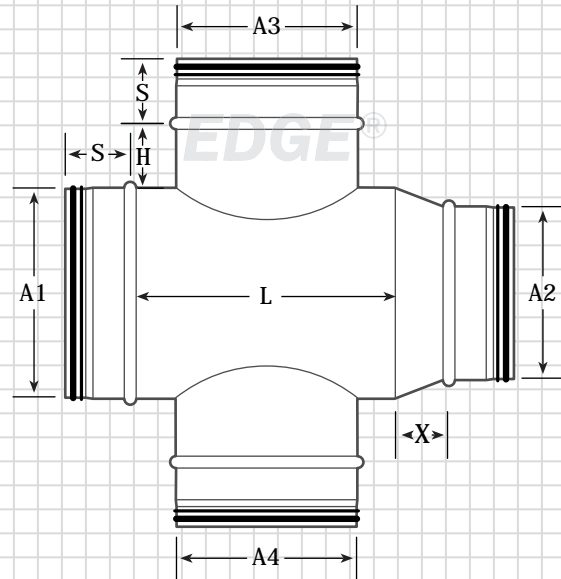

Gasket Reducing 45° Lateral Cross (GRCL)

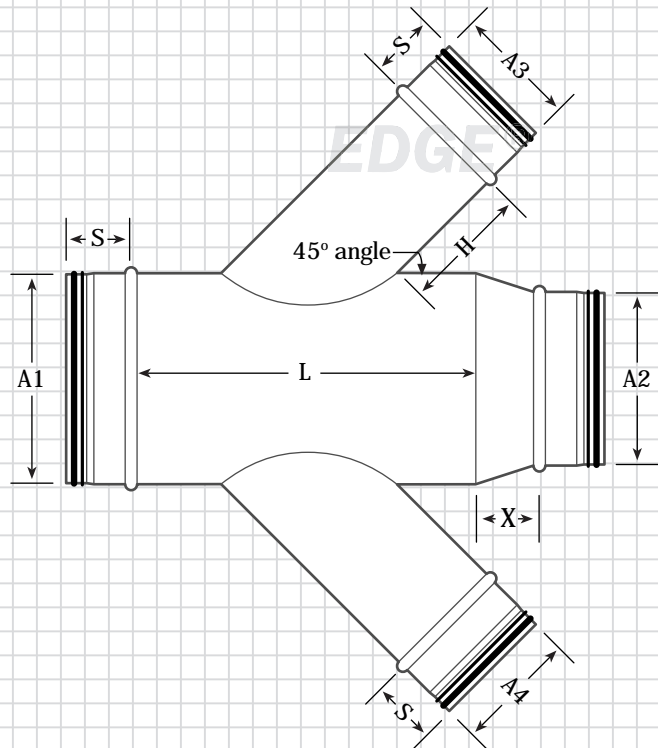

Key (All)

Sizes available for A1, A2, A3 & A4:
 4" - 10" (all sizes), 12" - 60" (even sizes only)
 A1 is greater than A3 & A4 (= 2" min.)
 A2 is less than A1
 A3 is greater than or equal to A4
 S = 2"
 H = 4"
 X = A1 - A2 (4" minimum)

Key (GRCC)

$L = A3 + 4"$

Key (GRCS)

$L = A3 + 4"$

Key (GRCL)

$L = (A3 \times 1.414) + 4"$

The EDGE® – Product Specifications

LoPro High Efficiency Take-off

Our LoPro High Efficiency Take-off is fabricated from 24 gauge G90 galvanized steel. This product is made with a low profile design to save room when installing on flat duct and to capture maximum air flow. The connection is The EDGE® self-sealing gasket which has been tested in accordance with SMACNA's Air Duct Leakage Test Manual and meets SMACNA Class 3 leakage standards. Products come standard with a peel-and-stick on the base.

(GLPHET) No Damper

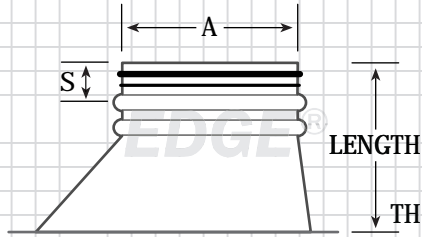

(GLPHETD) Standard Damper 5/8" Hardware

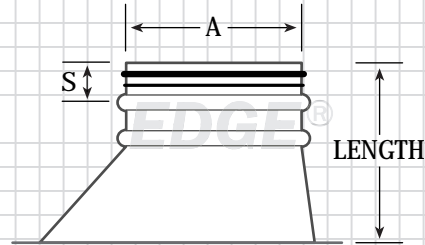

(GLPHETD2S) Standard Damper 5/8" Hardware with 2" Extension Kit

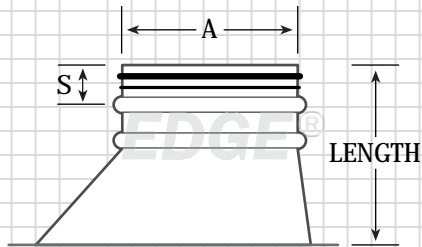

Dimensions

(A)	(S)	Inside Opening	Overall Length
4"	2"	4" x 6"	7.5"
5"	2"	5" x 7"	7.5"
6"	2"	5" x 8"	6.5"
7"	2"	6" x 9"	7"
8"	2"	7" x 10"	7"
9"	2"	8" x 11"	7"
10"	2"	9" x 12"	7"
12"	2"	11" x 14"	7"
14"	2"	13" x 16"	7"
16"	2"	14" x 22"	11"

(GLPHETDHD) Heavy Duty 2" Stand-off Locking Balancer Damper

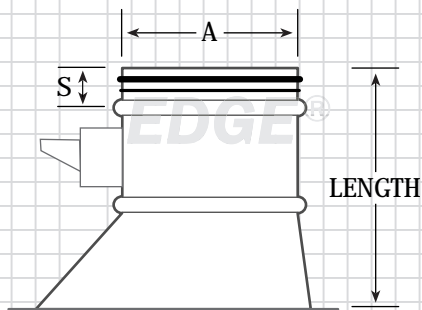

Dimensions

(A)	(S)	Inside Opening	Overall Length
4"	2"	4" x 6"	10"
5"	2"	5" x 7"	10"
6"	2"	5" x 8"	7"
7"	2"	6" x 9"	9"
8"	2"	7" x 10"	9"
9"	2"	8" x 11"	9"
10"	2"	9" x 12"	9"
12"	2"	11" x 14"	9"
14"	2"	13" x 16"	9.5"
16"	2"	14" x 22"	13.25"

The EDGE® – Product Specifications

Gasket Boot/Shoe Tap (GBTP)

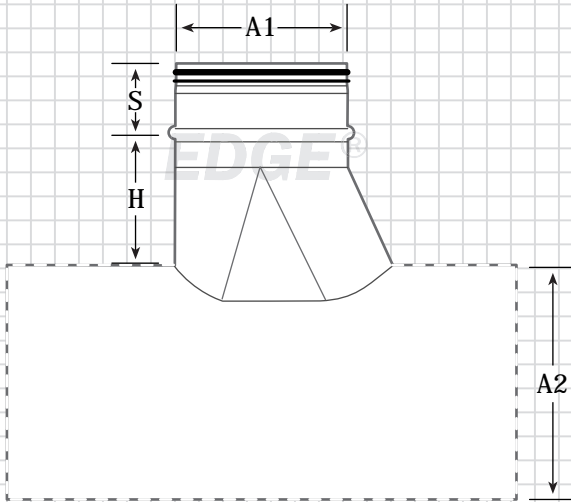

* Field installed fitting

Key (GBTP)

A1 = 4" - 10" (all sizes), 12" - 60" (even sizes only)

A2 is greater than or equal to A1

S = 2"

H = 2"

Options

Available with damper installed