

# Fume-A-Vent Motorized Hose Reels

Date 7/12

Part No. HRS-X-XXXX

Hose Reels

TAB 3-C

## MOTOR DRIVEN HOSE REEL SPECIFICATION HRM SERIES

### **MOTOR DRIVEN HOSE REEL SPECIFICATION**

Motor to be operated by a spring rocker switch standard, or optional 2-button switch. Rocker switch to be either mounted on the wall, column or switch can be wired directly to the hose reel and power cord dropped from the reel with the rocker switch mounted in box. Strain relief fittings to be used at both the box and junction on hose reel.

Two motor options are available depending on the hose requirements. The tube motor is a single phase UL approved, totally enclosed, 120V, 3.8 AMP, 430 Watt Motor Limit Switches, and Chain Drive mechanism. The direct drive motor is a planetary gear function motor - asynchronous, single phase, totally enclosed with 120V, 320 Watt, or an optional 230V, 390 Watt motor. More motor information available upon request.

The hose reel shall consist of the following features:

The hose reel side mounting support frame shall be constructed of 11 gauge cold rolled steel. The side plates shall be drawn securely together by two heavy gauge "J" channel steel support braces. Each side plate has two pre-drilled 9/16" diameter holes for the mounting of the hose reel.

The hose drum shall be constructed of 16 gauge cold rolled steel. The drum shall be formed and rolled to an 18" diameter and strengthened by four inner support bars. These bars are secured to the drum end flanges and pull the drum tightly against the end flange.

The drum end flanges shall be constructed of 16 gauge cold rolled steel. The end flange outer edge shall be rolled to provide strength and rigidity. Each end flange shall have a center pressed 18" diameter groove. This groove allows the reel drum and end flange to mate so the drum is always centered in relationship to the end flange. The drums's inner support bars draw the end flange securely to the drum for added strength, quality and reliability.

The hose reel shall have a hose to drum connection fitting allowing for use of either 4", 5", 6" or 8" hose. The connection fitting supports an inner 6" or 8" diameter tube that completes the connection from the extraction hose to the side discharge connection fittings. The side discharge fitting is a complete bearing fitting and allows for the connection of the 6" or 8" diameter discharge duct.

The hose reel drum shall also be supplied with a hose tracking bar to guide the hose during recoiling function.

The entire hose reel shall be protected by P & L Virtralon polyester powder coating for longevity and to resist corrosion.

The motor operated hose reel shall be equipped with a manual override on the motor.



AIR CLEANING SPECIALISTS, INC.  
11088 Gravois Industrial Ct. St. Louis MO 63128  
866 455-2132 Fax 636 349-0556  
www.fumeavent.com info@fumeavent.com

This drawing has been copyrighted  
and is the property of  
Air Cleaning Specialists, Inc.

## Fume-A-Vent Motorized Hose Reel

Date 7/12

Part No.HRM XX-XX-XX

Hose Reels

TAB 3-C-1



**Shown Above:** Fume-A-Vent Model HRM-2-0620 Motor Hose Reel with 5" x 20' Series 2 600° Rubber impregnated Polyester Hose. Plus the optional TPA04 Stainless Steel Tailpipe Adapter, Oval Mouth Neoprene for 4" & 5" Hose w/ Spring Clamp.

The reels are offered in standard 4,5,6 & 8 inch hose diameters. The Reels are supplied completely assembled and ready for installation. The Reels may be connected with ductwork to a central exhaust system or each Reel may be supplied with a direct moun fan.

Fume-A-Vent Hose Reels may be mounted in three positions: from an overhead support structure, or from a side support structure, and on the floor. Ceiling mounts are most common, however wall mounts and floor mounts are options when space is at a premium.

**FUME-A-VENT™**  
**EXHAUST REMOVAL SYSTEMS**  
A Product of Air Cleaning Specialists, Inc.

AIR CLEANING SPECIALISTS, INC.  
11088 Gravois Industrial Ct. St. Louis MO 63128  
800 455-2132 Fax 636 349-0556  
[www.fumeavent.com](http://www.fumeavent.com) [info@aircleaningspecialists.com](mailto:info@aircleaningspecialists.com)

This drawing has been copyrighted  
and is the property of  
Air Cleaning Specialists, Inc.

## Fume-A-Vent Motorized Hose Reel Dimensions

Date 7/12

Part No. HRM-X-XXXX

Hose Reels

TAB 3-C-2

Fume-A-Vent general dimensions for Motor Operated Hose Reels. Please note that depending on the diameter and length of the desired hose, the spring reels may be equipped with either 19, 28, 32 or 48 inch drum width, with overall width of 26, 35, 39 or 55 inches. We have reel specific dimensions pages and drawings available upon request.

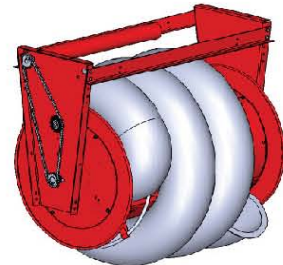
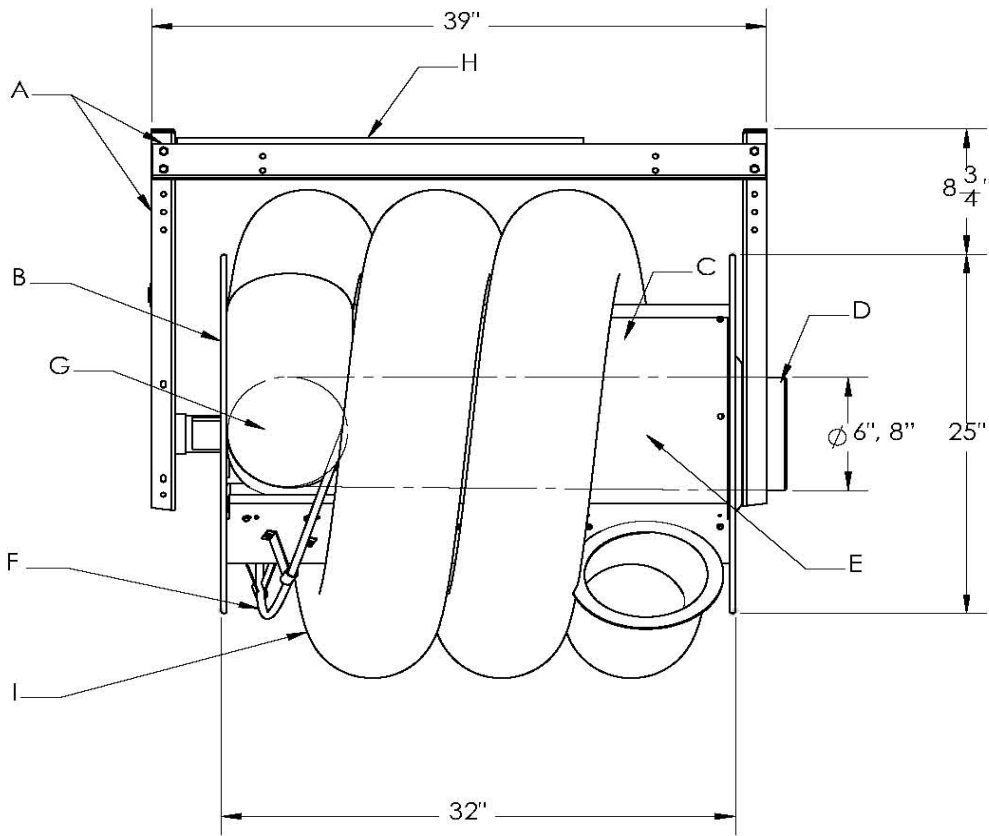

*\*Reel shown without hinged chain cover HRM-*

- |  |  |
|--|--|
| <p>A - Heavy Gauge Steel Support Mounting Frame<br/>                 B - End Flange<br/>                 C - Drum Assembly - 18" Diameter<br/>                 D - Duct Connection Fitting &amp; Bearing Assembly<br/>                 E - Internal Hose Tube - 6" or 8" Diameter<br/>                 F - Hose Tracking Bar<br/>                 G - Hose to Drum Connector - 4", 5", 6", 8" Diameter</p> | <p>H - Tube Motor<br/>                 I - Extraction Hose - 4", 5", 6", or 8" Diameters</p> <p>(Standard Hose Lengths are 16', 20', &amp; 24' ... Other Lengths are Available - Please Contact Factory)</p> |
|--|--|

Shown is the Fume-A-Vent Tube-Type Motorized Hose Reel - Part Number HRM-XX-0630-WT

| Model       | Hose Dia. | Max Hose Capacity | Drum Dia. | Drum Width    | Connection O.D. |
|-------------|-----------|-------------------|-----------|---------------|-----------------|
| HRM-XX-04XX | 4"        | 25' ; 40'         | 18"       | 19", 28"      | 6"              |
| HRM-XX-05XX | 5"        | 20' ; 34' ; 40'   | 18"       | 19", 28", 32" | 6"              |
| HRM-XX-06XX | 6"        | 20' ; 32' ; 36'   | 18"       | 19", 28", 32" | 6"              |
| HRM-XX-08XX | 8"        | 24' , 44'         | 18"       | 32", 48"      | 8"              |



**AIR CLEANING SPECIALISTS, INC.**  
 11088 Gravois Industrial Ct. St. Louis MO 63128  
 800 455-2132 Fax 636 349-0556  
[www.fumeavent.com](http://www.fumeavent.com) [info@fumeavent.com](mailto:info@fumeavent.com)

This drawing has been copyrighted and is the property of Air Cleaning Specialists, Inc.

# Fume-A-Vent Motorized Hose Reels Operating Instruction

Date 7/12

Part No. HRM

Hose Reels

TAB 3-C-3

## Operating and Installation Instructions Series HRM Exhaust Reels

### SAFETY:

Personal Injury and/or equipment damage may result if proper safety precautions are not observed.

- Ensure that reel is properly installed before connecting input and output hoses.
- Ensure that working pressure and temperature do not exceed rating of reel.
- Be aware of machinery and personnel in work area.
- If a leak occurs in the hose or reel, remove from service immediately.
- A high powered motor is enclosed in the side cover, exercise caution around chain and motor.
- If reel ceases to unwind or rewind, disconnect from service immediately
- Other than replacing the hoses, refer all other repairs only to an authorized service person or directly to Fume-A-Vent. Failure to do so may void the warranty.

### MOUNTING:

- See Tab 3-I for Installation Guide

### CONNECTING HOSES

- Mount hose reel using mounting holes (9/16") (1)
- Position input hose to input adaptor (2). Secure into place with hose clamp (3).
- Position output hose to output adaptor (4). Secure into place with hose clamp (5).
- Connect power to motorized hose reel

NOTE: Never obstruct or alter the speed at which the hose retracts. The motor will be damaged if improper use occurs.

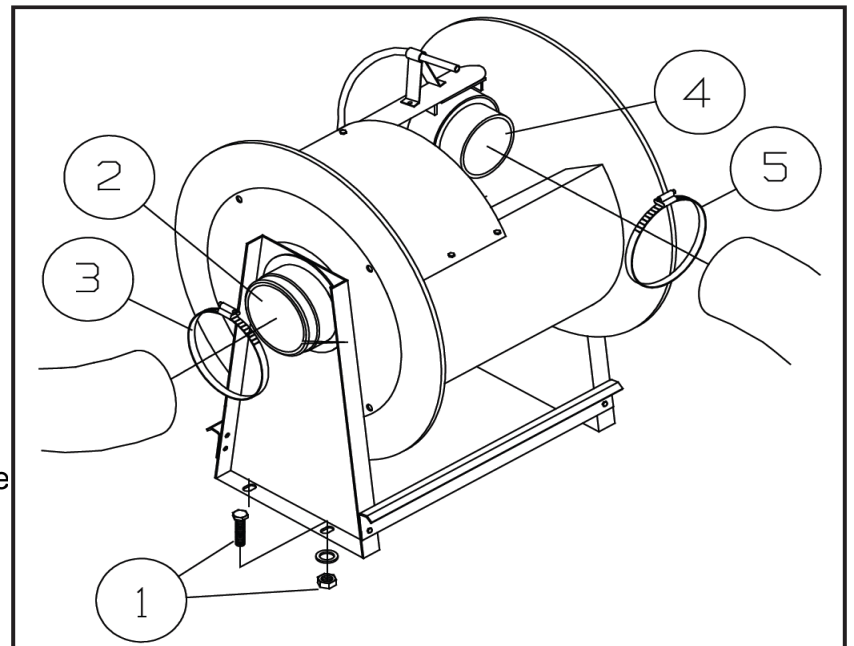

CAUTION: When adding wraps of hose, be careful not to exceed the winding mechanism's spring capacity. Add just enough wraps of hose to achieve the desired tension. Damage to the winding mechanism and motor will result if spring is over-tensioned.

# Fume-A-Vent Motorized Hose Reel Information

Date 7/12

Part No. N/A

Hose Reels

TAB 3-C-4

## Box Motor Assembly Information

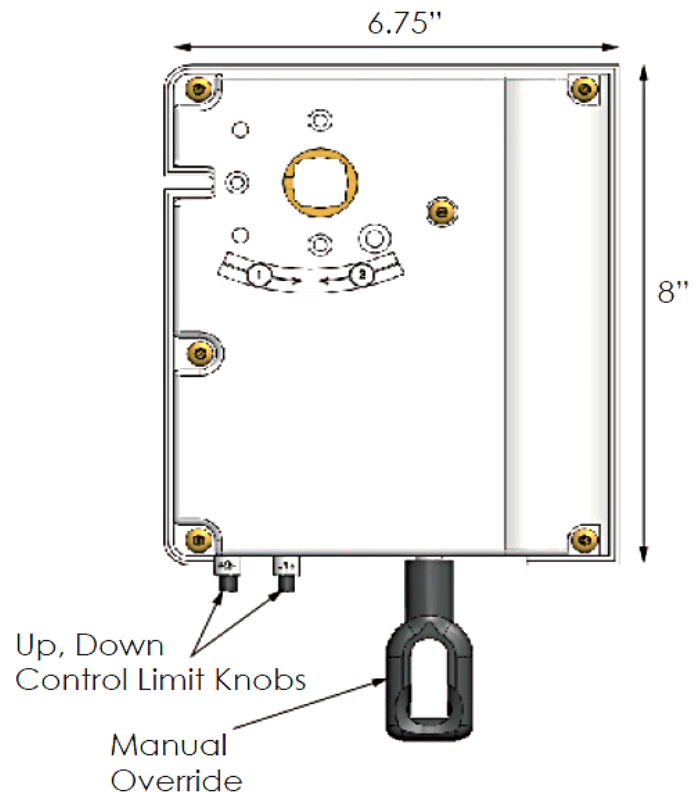
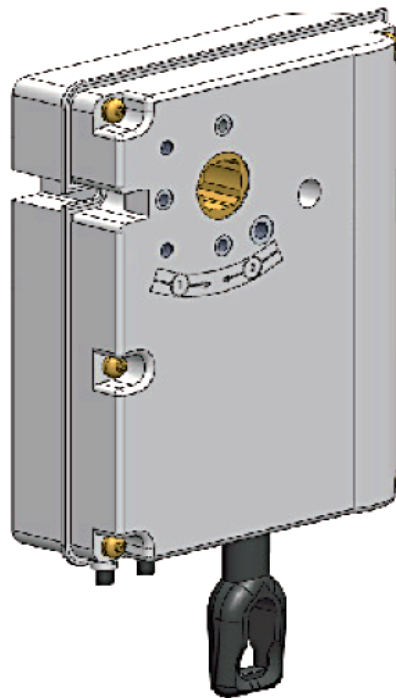

### Product Features and Specifications:

**MOTOR:** Direct Drive Planetary Gear - Asynchronous, Single Phase Totally Enclosed  
Standard: 120V, 60HZ, 2.7A, 320W - 14 RPM  
Optional: 230V, 60 HZ, 1.8A, 390W - 12 RPM

**UNIT:** Built In Start Run Capacitor - Built In Brake - Built In Up/Down Limit Control Knobs (38 Turns) - Anti-corrosion Coating - Manual Override (Ratio: 1/26) - Weighs 12 Pounds - 3/4 Inch Square Drive Shaft.

**SWITCH:** Motor Unit Supplied with Double Pole Spring Rocker Switch. Switch has arrow marking for Up/Down and automatically returns to center, which is neutral position. Switch also supplied with Switch Plate and can be wall or column mounted. Switch can be directly hung from reel using power cord and proper strain relief fittings upon request.