

Fume-A-Vent Automatic Damper for Hose Reels

Date 7/12

Part No. HRC-DMD-X

Hose Reels

TAB 3-M

The Automatic Hose Reel Dampers feature an automatic shut off system that will stop air flow when the hose is retracted back onto the hose reel and open back up when the hose is retracted again. It can be a necessity for ceiling mounted application or with overhead cranes. They are a direct fit to the hose reel so that no additional equipment, or hardware is required. Normally these dampers are installed on the hose reel by the factory but are also available separate. The damper itself is made to handle the same temperatures and stress



Pictured Above: The Automatic Hose Reel Mounted Damper with 6 Inch Diameter
Shown Below: Orthographic Views of the Automatic Damper

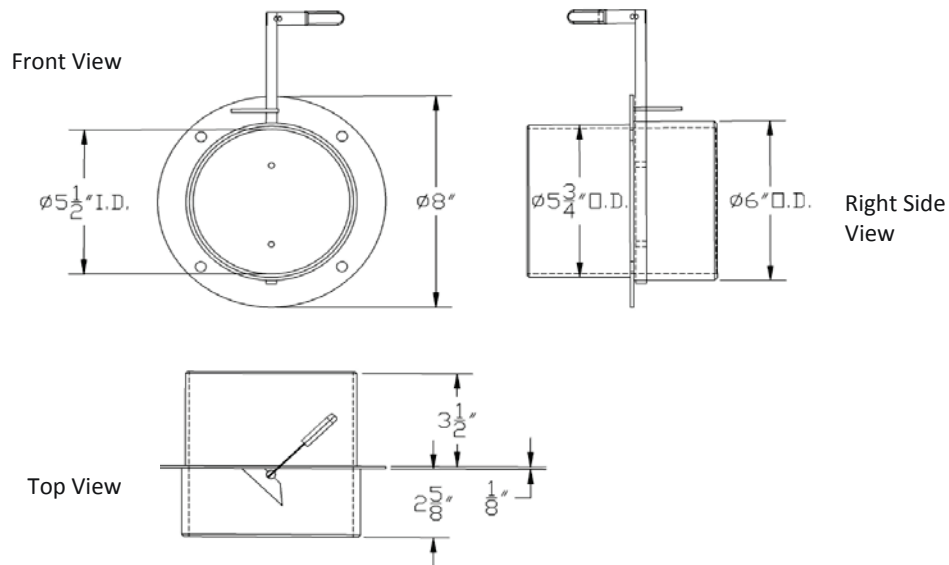

Part Number	Price	Description	Sizes
HRC-DMD-6	\$350	Fume-A-Vent Direct Mount Damper for 6 Inch Reels	6 Inch O.D.
HRC-DMD-8	\$350	Fume-A-Vent Direct Mount Damper for 8 Inch Reels	8 Inch O.D.