

Fume-A-Vent Motorized Hose Reel

Date 7/12

Part No.HRM XX-XX-XX

Hose Reels

TAB 3-C-1



Shown Above: Fume-A-Vent Model HRM-2-0620 Motor Hose Reel with 5" x 20' Series 2 600° Rubber impregnated Polyester Hose. Plus the optional TPA04 Stainless Steel Tailpipe Adapter, Oval Mouth Neoprene for 4" & 5" Hose w/ Spring Clamp.

The reels are offered in standard 4,5,6 & 8 inch hose diameters. The Reels are supplied completely assembled and ready for installation. The Reels may be connected with ductwork to a central exhaust system or each Reel may be supplied with a direct moun fan.

Fume-A-Vent Hose Reels may be mounted in three positions: from an overhead support structure, or from a side support structure, and on the floor. Ceiling mounts are most common, however wall mounts and floor mounts are options when space is at a premium.

FUME-A-VENT™
EXHAUST REMOVAL SYSTEMS
A Product of Air Cleaning Specialists, Inc.

AIR CLEANING SPECIALISTS, INC.
11088 Gravois Industrial Ct. St. Louis MO 63128
866 455-2132 Fax 636 349-0556
www.fumeavent.com info@aircleaningspecialists.com

This drawing has been copyrighted
and is the property of
Air Cleaning Specialists, Inc.

Fume-A-Vent Motorized Hose Reels

Date 7/12

Part No. HRS-X-XXXX

Hose Reels

TAB 3-C

MOTOR DRIVEN HOSE REEL SPECIFICATION HRM SERIES

MOTOR DRIVEN HOSE REEL SPECIFICATION

Motor to be operated by a spring rocker switch standard, or optional 2-button switch. Rocker switch to be either mounted on the wall, column or switch can be wired directly to the hose reel and power cord dropped from the reel with the rocker switch mounted in box. Strain relief fittings to be used at both the box and junction on hose reel.

Two motor options are available depending on the hose requirements. The tube motor is a single phase UL approved, totally enclosed, 120V, 3.8 AMP, 430 Watt Motor Limit Switches, and Chain Drive mechanism. The direct drive motor is a planetary gear function motor - asynchronous, single phase, totally enclosed with 120V, 320 Watt, or an optional 230V, 390 Watt motor. More motor information available upon request.

The hose reel shall consist of the following features:

The hose reel side mounting support frame shall be constructed of 11 gauge cold rolled steel. The side plates shall be drawn securely together by two heavy gauge "J" channel steel support braces. Each side plate has two pre-drilled 9/16" diameter holes for the mounting of the hose reel.

The hose drum shall be constructed of 16 gauge cold rolled steel. The drum shall be formed and rolled to an 18" diameter and strengthened by four inner support bars. These bars are secured to the drum end flanges and pull the drum tightly against the end flange.

The drum end flanges shall be constructed of 16 gauge cold rolled steel. The end flange outer edge shall be rolled to provide strength and rigidity. Each end flange shall have a center pressed 18" diameter groove. This groove allows the reel drum and end flange to mate so the drum is always centered in relationship to the end flange. The drums's inner support bars draw the end flange securely to the drum for added strength, quality and reliability.

The hose reel shall have a hose to drum connection fitting allowing for use of either 4", 5", 6" or 8" hose. The connection fitting supports an inner 6" or 8" diameter tube that completes the connection from the extraction hose to the side discharge connection fittings. The side discharge fitting is a complete bearing fitting and allows for the connection of the 6" or 8" diameter discharge duct.

The hose reel drum shall also be supplied with a hose tracking bar to guide the hose during recoiling function.

The entire hose reel shall be protected by P & L Virtralox polyester powder coating for longevity and to resist corrosion.

The motor operated hose reel shall be equipped with a manual override on the motor.



AIR CLEANING SPECIALISTS, INC.
11088 Gravois Industrial Ct. St. Louis MO 63128
866 455-2132 Fax 636 349-0556
www.fumeavent.com info@fumeavent.com

This drawing has been copyrighted
and is the property of
Air Cleaning Specialists, Inc.

Fume-A-Vent Hose Reel Mounting

Date 7/12

Part No. HRX-X-XXXX

Hose Reels

TAB 3-B-5

This is a drawing of the typical mounting positions that our Fume-A-Vent Hose Reels are placed. They are easily installed with the four mounting holes that are 9/16" by 3/4" deep. Unistrut can be utilized effectively with the mounting holes or by other methods. Please consult one of our experts to decide the best mounting type for your application. Both Spring and Motorized Hose Reels have the same mounting options and

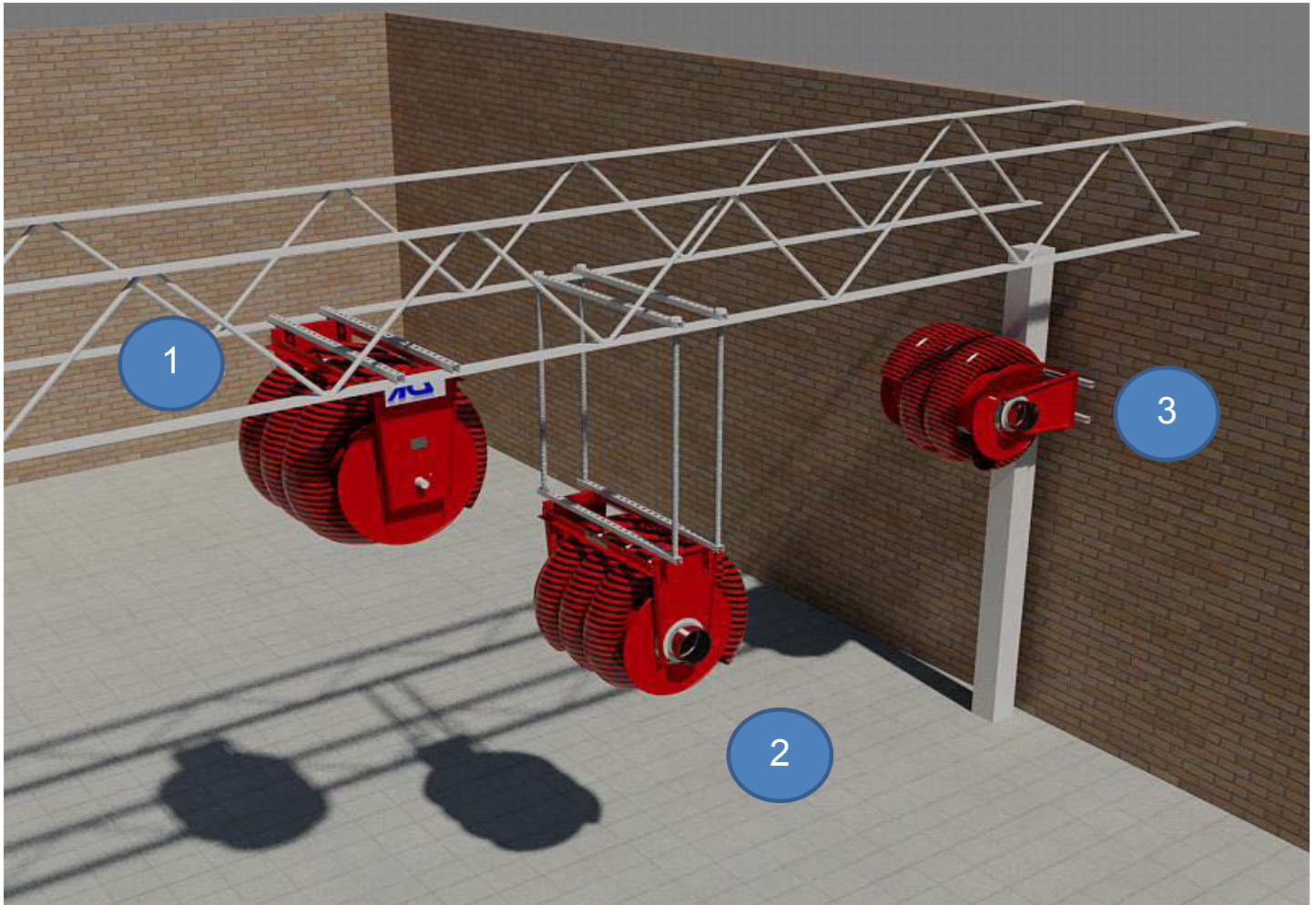

1. Ceiling mounting utilizing the Unistrut Steel Hangers.
2. Dropped down ceiling mount with Unistrut and 1/2" threaded rod for drop.
3. Wall mounted hose reel with Unistrut supports.

Installation Guides available upon request for most ceiling types including joist and concrete.

Hose Reels are a heavy item that has pull/push force from the spring retention. Please make sure the hose reel is mounted in a secure, strong location. Methods other than Unistrut and threaded rod are available.

Fume-A-Vent Type 3 400°F Polyester Impregnated Rubber Hose

Date 7/12

Part No. H-03-XXXX

Type 3 400°F Hose

TAB 1-C

The Fume-A-Vent Type 3 Hose ideal is for hose reels, overhead and underground fume extraction systems, plus welding, industrial use, light-duty material handling, and agricultural use. This hose features a low static pressure.

Temperature Range: -5°F to 350°F (Baking Test)

This product meets Flame retardant UL-94 VO and federal motor vehicle MVSS-302 test standards

The Temperature Rating has been tested to withstand up to 550°F (intermittent use) and 350°F continuous duty.

Both before and after heat testing, the Type 3 Hose tested for an identical rating of 497-pounds on the static pull/stress test.

It is made with high quality polyester impregnated rubber with fully enclosed wire helix. The method of manufacturing is a hot air welding process that does not use any type of adhesives/glues. The hose is manufactured with an additional outer wear strip for protection and longevity. It has good flexibility, good abrasion resistance, and low flow resistance. It is abrasion-resistant with strong characteristics against weather, oils and ozone.

Other information including wall thickness and helix pitch are available upon request. In some cases, a Fan and a Tailpipe Adaptor will be required. Common lengths and diameters shown in chart below.

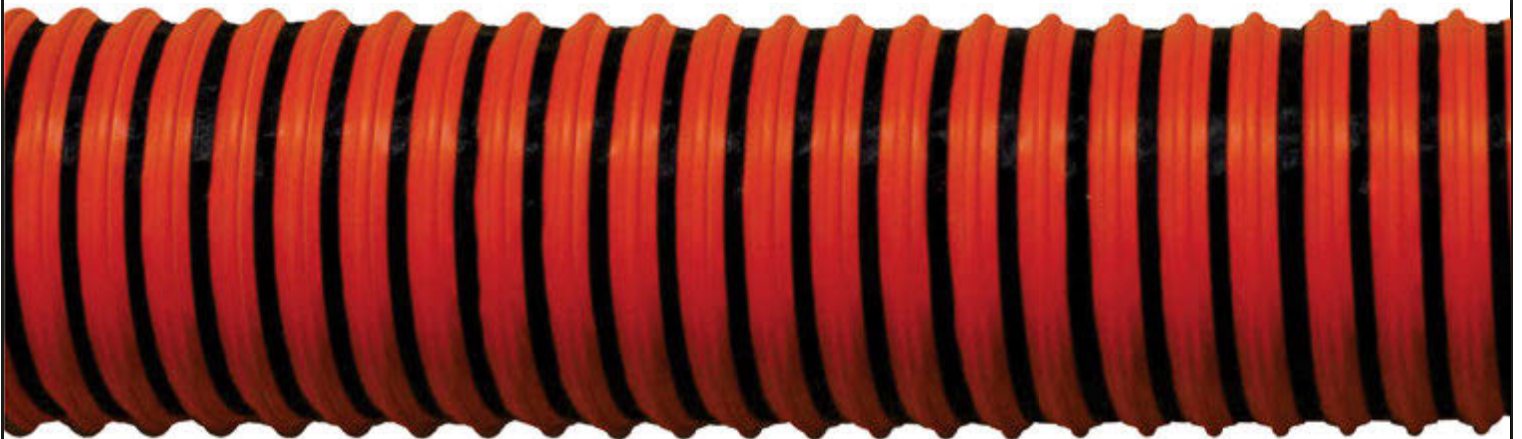

Part No	Description	Lbs.
H-03-0310	Fume-A-Vent 3" x 10' Type 3 400°F Polyester Impregnated Rubber High Temperature Hose	9
H-03-0410	Fume-A-Vent 4" x 10' Type 3 400°F Polyester Impregnated Rubber High Temperature Hose	15
H-03-0420	Fume-A-Vent 4" x 20' Type 3 400°F Polyester Impregnated Rubber High Temperature Hose	15
H-03-0425	Fume-A-Vent 4" x 25' Type 3 400°F Polyester Impregnated Rubber High Temperature Hose	18
H-03-0510	Fume-A-Vent 5" x 10' Type 3 400°F Polyester Impregnated Rubber High Temperature Hose	15
H-03-0520	Fume-A-Vent 5" x 20' Type 3 400°F Polyester Impregnated Rubber High Temperature Hose	16
H-03-0525	Fume-A-Vent 5" x 25' Type 3 400°F Polyester Impregnated Rubber High Temperature Hose	18
H-03-0610	Fume-A-Vent 6" x 10' Type 3 400°F Polyester Impregnated Rubber High Temperature Hose	15
H-03-0620	Fume-A-Vent 6" x 20' Type 3 400°F Polyester Impregnated Rubber High Temperature Hose	16
H-03-0625	Fume-A-Vent 6" x 25' Type 3 400°F Polyester Impregnated Rubber High Temperature Hose	18
H-03-0810	Fume-A-Vent 8" x 10' Type 3 400°F Polyester Impregnated Rubber High Temperature Hose	16
H-03-0820	Fume-A-Vent 8" x 20' Type 3 400°F Polyester Impregnated Rubber High Temperature Hose	17
H-03-0825	Fume-A-Vent 8" x 25' Type 3 400°F Polyester Impregnated Rubber High Temperature Hose	20



Air Cleaning
Specialists Inc.
11088 Gravois Ind. Ct.
St. Louis MO 63128
636-349-4400
636-349-0556 Fax

TOP VIEW

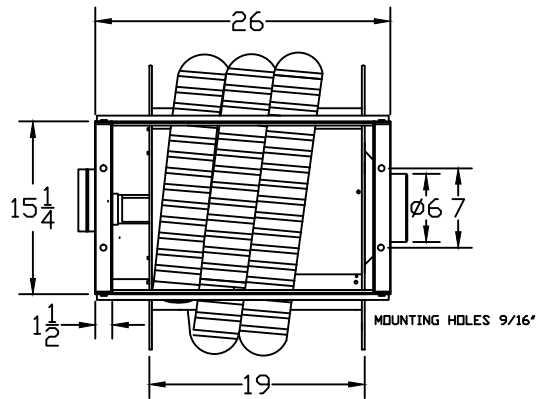

MOTORIZED HOSE REEL
HRM-3-0420
4" 400° HOSE/ 20' LENGTH

SIDE VIEW

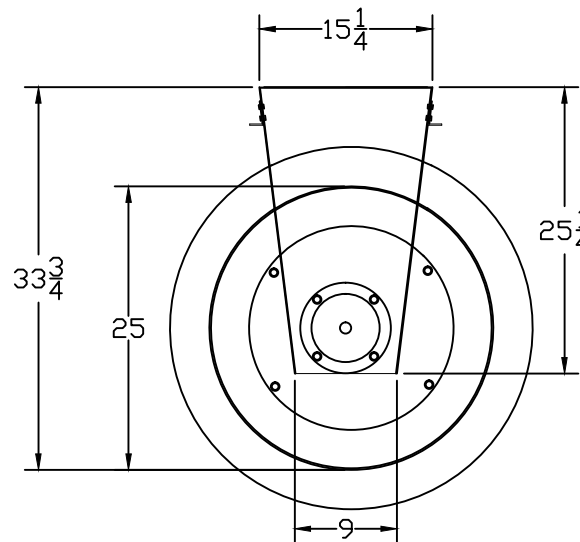
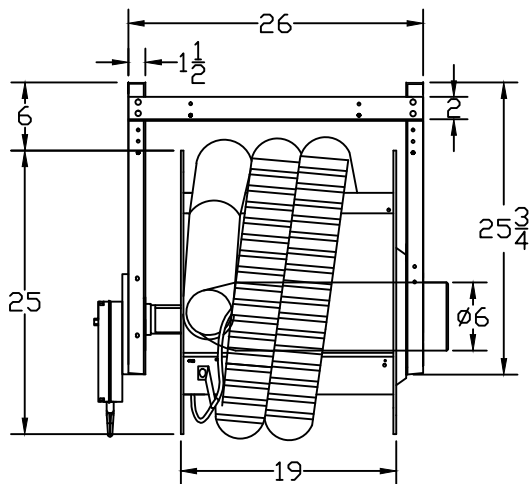

REVISIONS

1	

SHEET NAME
1



DRAWING TITLE
HRM-3-0420

DRAWN: CODY BINGAMAN

CHECKED: JIM GRAYEM

PROJECT NAME
HOSE REEL

DATE
9/12/12

VIEW
 ORTHO

SIZE
A

DWG NO.
1

REV.
0

SCALE: 1:1 WEIGHT: 1 SHEET 1 OF 0